

POSITION VERTICALLY W/CROSSPOINTS FACING E-W

For Experimental Detection of Natural ULF Energy Phenomena.

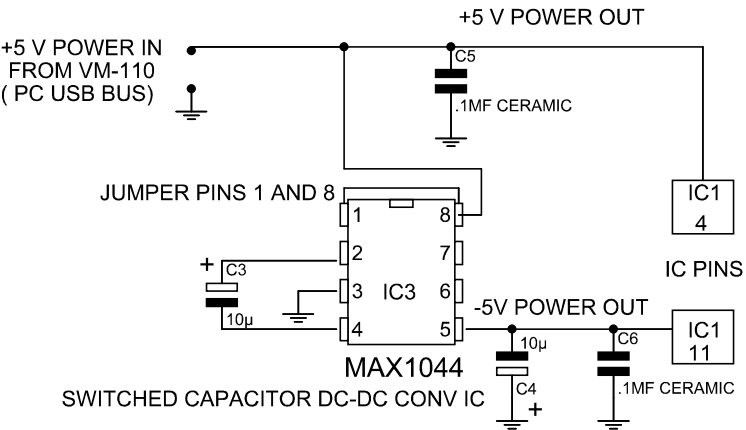
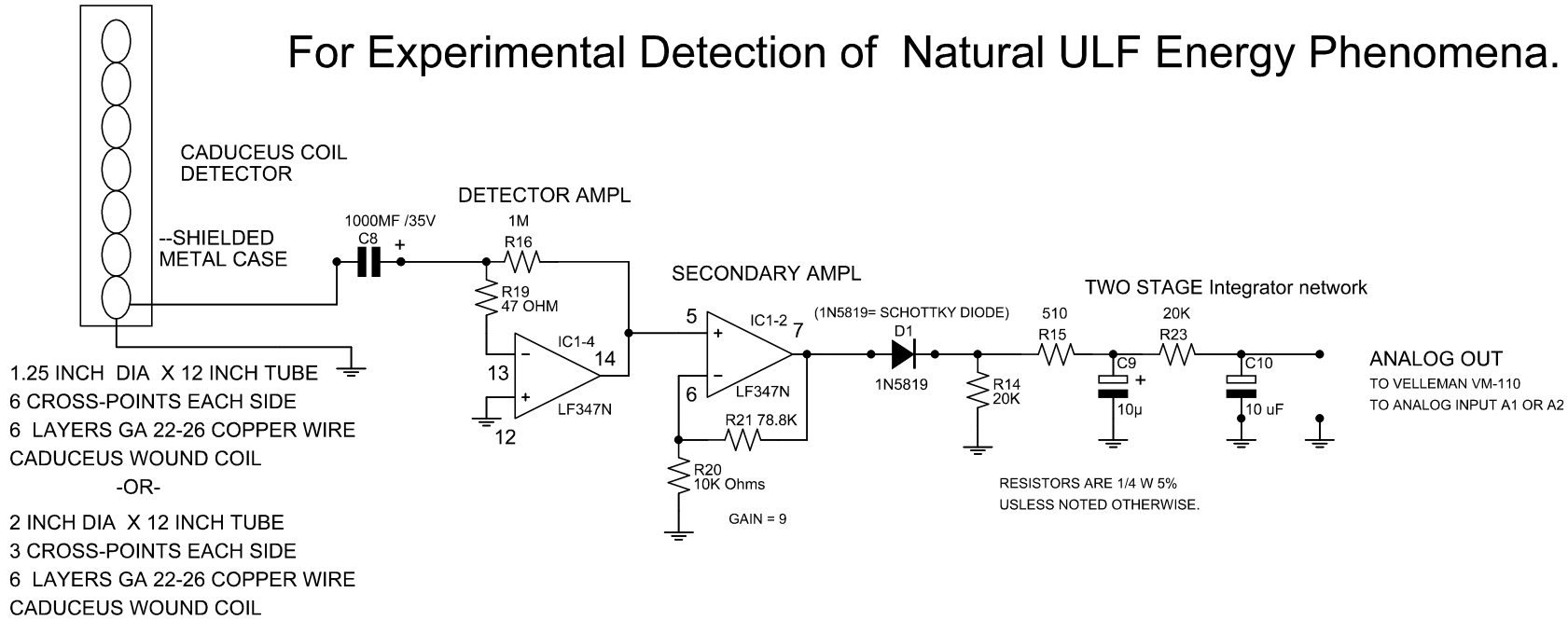

ULTRA LOW FREQUENCY CADUCEUS DETECTOR CIRCUIT

THIS CIRCUIT IS DESIGNED FOR SCIENTIFIC USE IN THE DETECTION OF ULTRA LOW FREQUENCY MAGNETIC ACTIVITY.

IT IS DESIGNED TO BE INTERFACED WITH A VELLEMAN VM-110 / K8055 A TO D AND PC USB INTERFACE BOARD AND TO USE REALVIEW 2.0 OR 3.0 CHART RECORDER SOFTWARE BY ABACOM OR SIMILAR A TO D SYSTEMS AND SOFTWARE.

Tony Devencenzi / Peter Newton REV 02/15/2013