

For Experimental Detection of ULF Electric Activity

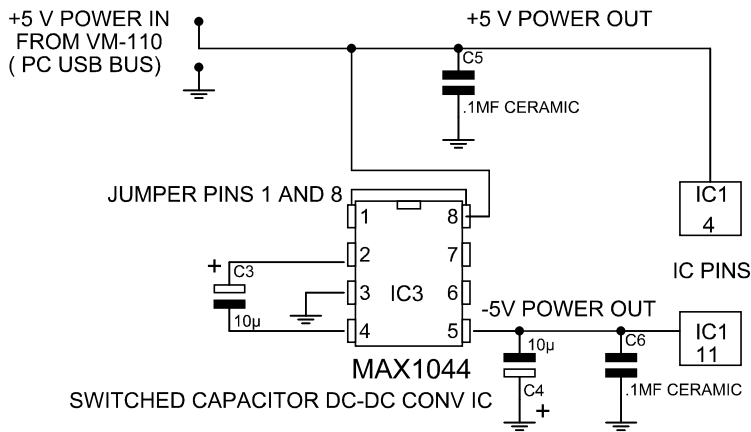
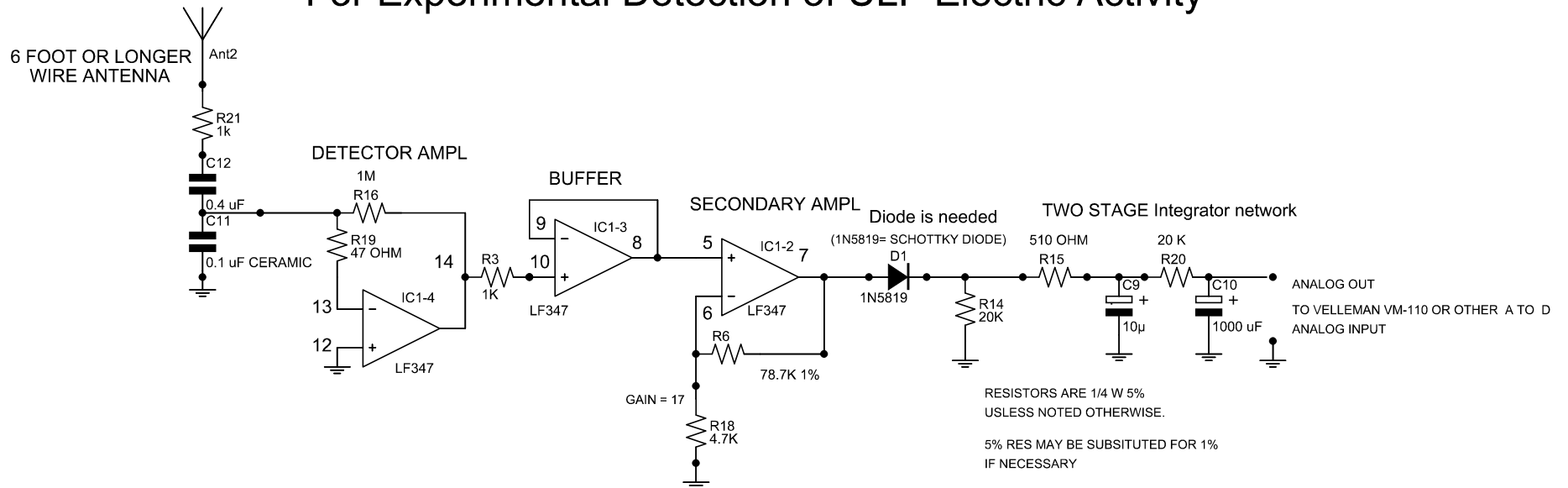

E-FIELD ANTENNA ELECTRON SENSOR WITH LONG TIME CONSTANT INTEGRATOR

THIS CIRCUIT IS DESIGNED FOR SCIENTIFIC USE IN THE DETECTION OF ULTRA LOW FREQUENCY ELECTRIC ACTIVITY

IT IS DESIGNED TO BE INTERFACED WITH A VELLEMAN VM-110 / K8055 A TO D AND PC USB INTERFACE BOARD OR OTHER A TO D UNITS AND TO USE I F 3.0 CHART RECORDER SOFTWARE BY ABACOM OR OTHER SOFTWARE CHART THAT WILL WORK WITH THE A TO D CONVERTER USED.

TONY DEVENCENZI frostalarm@att.net