

For Experimental Detection of Solar and Galactic Energies.

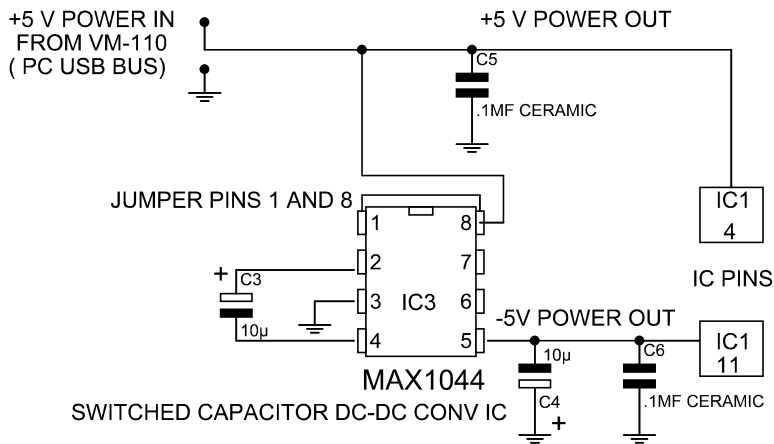
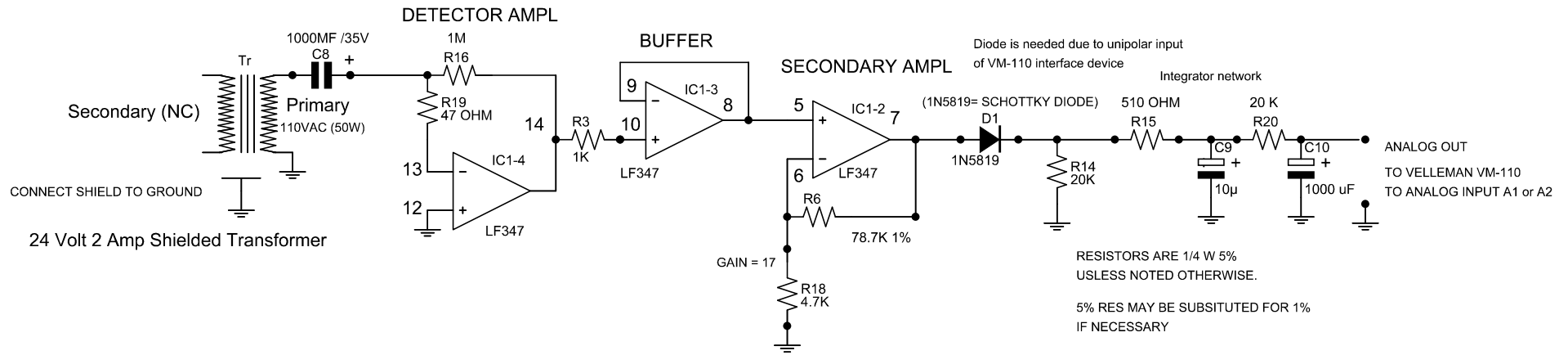

THIS CIRCUIT IS DESIGNED FOR SCIENTIFIC USE
IN THE DETECTION OF ULTRA LOW FREQUENCY MAGNETIC ACTIVITY

IT IS DESIGNED TO BE INTERFACED WITH A VELLEMAN VM-110 / K8055
A TO D AND PC USB INTERFACE BOARD AND TO USE REALVIEW
3.0 CHART RECORDER SOFTWARE BY ABACOM.

TONY DEVENCENZI frostalarm@att.net